



SERIES: **FIRG-Q**

INTERCHANGE: ISO 16028 and NFPA T3.20.15 (HTMA)

MAIN APPLICATIONS

- Industrial equipment
- Cooling systems
- Steel industry

The "FIRG-Q" flat-face couplings series is the solution for mildly corrosive environments and/or for relatively corrosive fluid transfer (ex.: sweet water, water and glycol etc).

Products are manufactured in carbon steel and treated with special nitriding and oxidation treatment.

The internal valve material is stainless steel AISI303 and can be supplied with a variety of seals for fluid compatibility and operating temperature requirements.

The flat face design eliminates leakage during connection-disconnection and reduces contamination in the circuit. The combined features of the flat face design with greater resistance to corrosion makes "FIRG-Q" series ideal for several applications, mainly in the industrial field.



Stucchi[®]

A CONSTANT FLOW OF SOLUTIONS

SERIES: FIRG-Q

TECHNICAL FEATURES AND OPTIONS

- Interchangeability: ISO 16028 (from size 6.3 to 25) HTMA (size 10)
- Valve system: Flat face
- Mechanical connection: Locking balls
- Connection system: Push to connect
- Disconnection system: Pulling back the sleeve of female
- Connection with residual pressure: Not allowed
- Disconnection with residual pressure: Not allowed
- Threads available: BSP, NPT
- Threads on request: SAE (J1926-1)
- Construction material: High resistance carbon steel with special treatment nitriding + oxidation (QPQ)
- Internal valves in AISI 303
- Spring: AISI 302
- Locking Ball material: AISI 420
- Seals: NBR (Nitrile), VITON, EPDM and KALREZ
- Seals on request: HNBR or others
- Anti-extrusion rings: PTFE

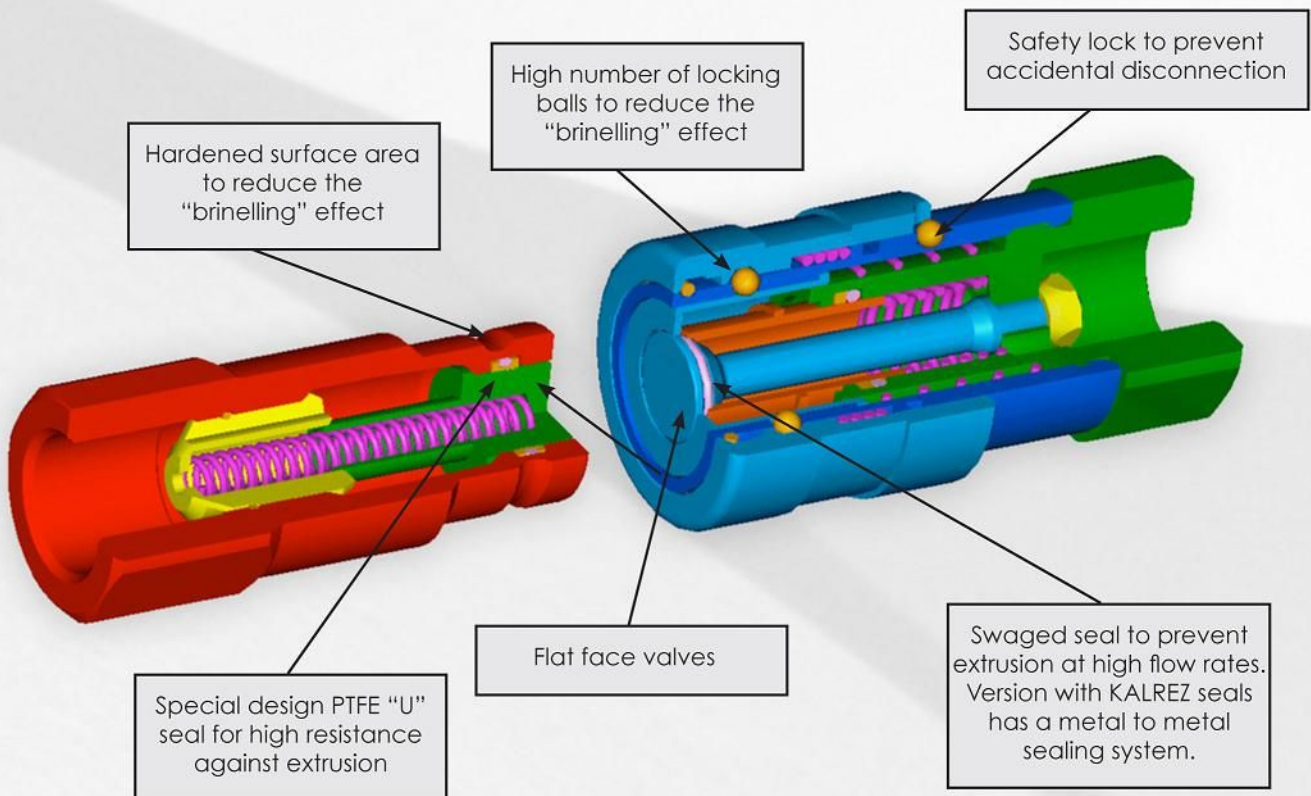

BENEFITS

- Flat face is easy to clean, helping to reduce the inclusion of contamination to the hydraulic circuit.
- Minimal fluid loss during connection / disconnection, reducing fluid loss to the environment.
- Minimal air inclusion during connection / disconnection, enhancing correct function of the circuit.
- Linear flow reduces internal turbulence and pressure drop, maintaining circuit efficiency in the entire system.
- Superior corrosion resistance compared to zinc plating in specific corrosive environments.
- Good resistance at impulse pressures.
- Compact slim design.
- Safe and simple to use.

SERIES: FIRG-Q

HOW TO USE

- Before to couple clean the flat mating surface of quick coupling to avoid the inclusion of dirty in the circuit.
- To couple push the male half towards the female half or vice versa.
- After connection turn the external sleeve to engage lock function, to prevent accidental disconnection.
- To uncouple turn the external sleeve until the sleeve lock groove corresponds with the safety lock ball and pull back the sleeve.

WARNING!

- Do not use the female coupling disconnected with impulse pressure.
- Do not couple-uncouple with flow and/or pressure in the circuit.
- Do not couple-uncouple when the temperature inside of the circuit is higher than 80 °C (176 °F).
- When the couplings are disconnected, it is suggested to use the protection caps.
The plastic caps for "FIRG-A" series are suitable with "FIRG-Q" couplings.

PERFORMANCE

Description	Size	ISO Size	Rated flow		Max. flow suggested		Connect force		Disconnect force		Spillage*
			l/min	GPM	l/min	GPM	N	lbf	N	lbf	
FIRG14Q	1/4	6,3	12	3,18	24	6,36	130	29,25	45	10,13	0,006
FIRG38Q-12Q	3/8	10,0	23	6,10	46	12,19	160	36,00	35	7,88	0,012
FIRG12A-34Q	1/2	12,5	45	11,93	90	23,85	240	54,00	65	14,63	0,020
FIRG34BQ	5/8	16,0	74	19,61	148	39,22	190	42,75	60	13,50	0,026
FIRG100Q	3/4	19,0	100	26,50	200	53,00	220	49,50	70	15,75	0,032
FIRG114Q	1	25,0	189	50,09	378	100,17	310	69,75	100	22,50	0,035
FIRG112Q	1-1/2	-	288	76,32	750	198,75	400	90,00	100	22,50	0,050
FIRG200Q	2	-	379	100,44	1000	265,00	370	83,25	70	15,75	0,100

(Data valid for couplings with NBR, VITON, EPDM seals)

Description	Max. operating pressure						Burst pressure					
	Coupled		Male		Female		Coupled		Male		Female	
	MPa	psi	MPa	psi	MPa	psi	MPa	psi	MPa	psi	MPa	psi
FIRG14Q	30	4350	30	4350	12	1740	120	17400	120	17400	48	6960
FIRG38Q-12Q	30	4350	30	4350	15	2175	120	17400	120	17400	60	8700
FIRG12A-34Q	25	3625	25	3625	12	1740	100	14500	100	14500	48	6960
FIRG34BQ	25	3625	25	3625	12	1740	100	14500	100	14500	48	6960
FIRG100Q	25	3625	25	3625	10	1450	100	14500	90	13050	40	5800
FIRG114Q	25	3625	25	3625	10	1450	100	14500	90	13050	40	5800
FIRG112Q	20	2900	20	2900	8	1160	60	8700	60	8700	32	4640
FIRG200Q	20	2900	20	2900	8	1160	60	8700	60	8700	32	4640

(Data valid for couplings with KALREZ seals for high temperature)

Description	Max. operating pressure						Burst pressure					
	Coupled		Male		Female		Coupled		Male		Female	
	MPa	psi	MPa	psi	MPa	psi	MPa	psi	MPa	psi	MPa	psi
FIRG14QK	5	725	5	725	5	725	120	17400	120	17400	40	5800
FIRG38-12QK	5	725	5	725	5	725	120	17400	120	17400	48	6960
FIRG12A-34QK	5	725	5	725	5	725	100	14500	100	14500	48	6960
FIRG34BQK	5	725	5	725	5	725	100	14500	100	14500	40	5800
FIRG100QK	5	725	5	725	5	725	100	14500	90	13050	60	8700
FIRG114QK	5	725	5	725	5	725	100	14500	90	13050	60	8700
FIRG112QK	5	725	5	725	5	725	40	5800	40	5800	32	4640
FIRG200QK	5	725	5	725	5	725	40	5800	40	5800	32	4640

* Spillage is an indicative value of the fluid loss per couple-uncouple cycle.

- Temperature range:
 - NBR (Nitrile) selas: from -20 °C to +100 °C (from -4 °F to +212 °F).
 - VITON seals: from -15°C to +180°C (from +5 °F to +356 °F).
 - EPDM (Ethylene Propylene) seals: from -40°C to +150°C (from -40 °F to +302 °F).
 - KALREZ seals: from -25°C to +300°C (from -13 °F to +572 °F).

- Tests:
 - The couplings have been tested at max. operating pressure for 100'000 impulses in according with ISO 7241-2.

PRESSURE DROP

TESTS ESEGUITI IN CONFORMITA' A ISO 7241-2
 TESTS IN ACCORDANCE WITH ISO 7241-2

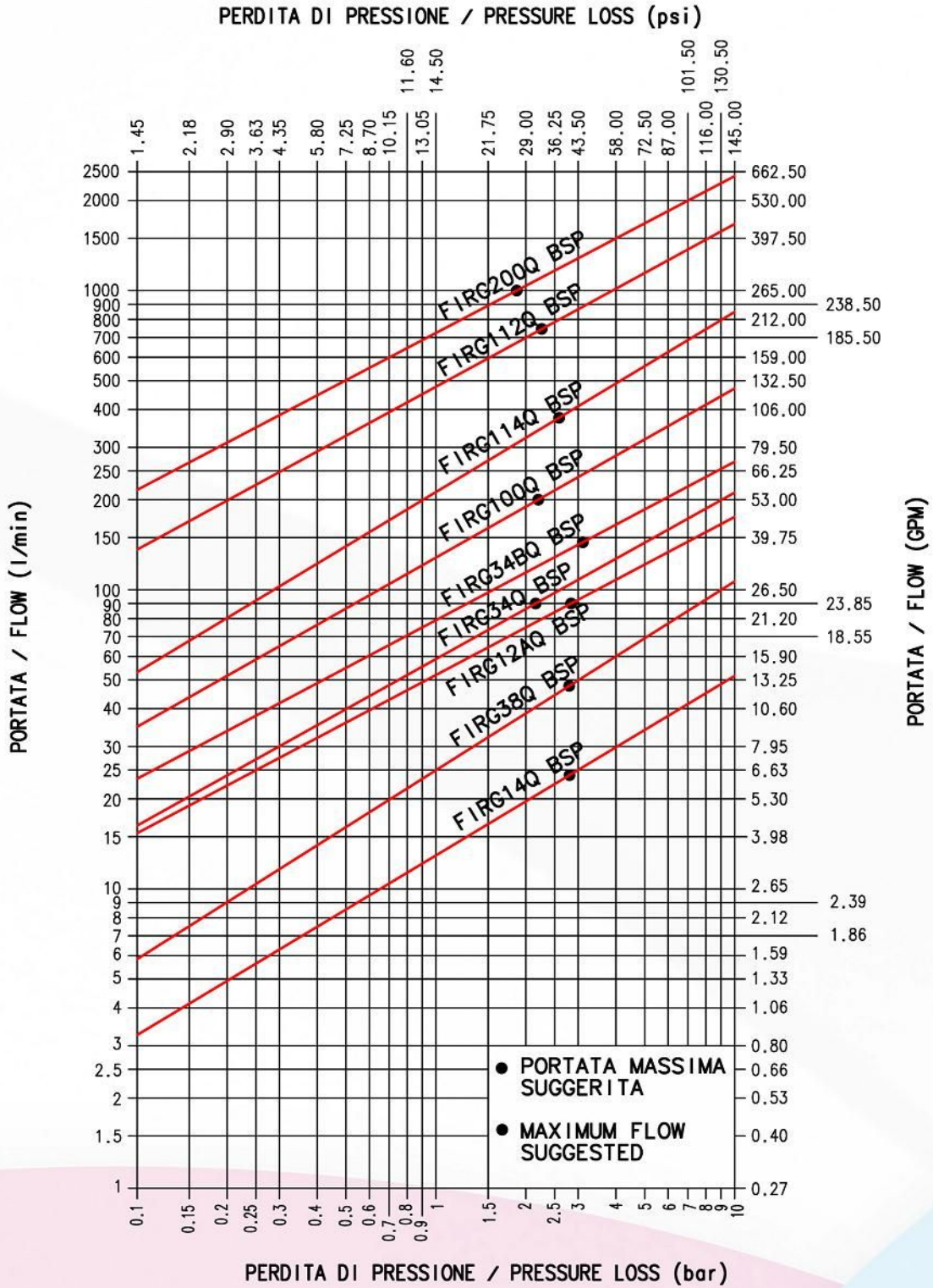

FLUIDO: OLIO ISO VG32
 TEMPERATURA: 40°C
 VISCOSITA': 28.8-35.2 mm²/s

FLUID: OIL ISO VG32
 TEMPERATURE: 40°C
 VISCOSITY: 28.8-35.2 mm²/s

OVERALL DIMENSIONS

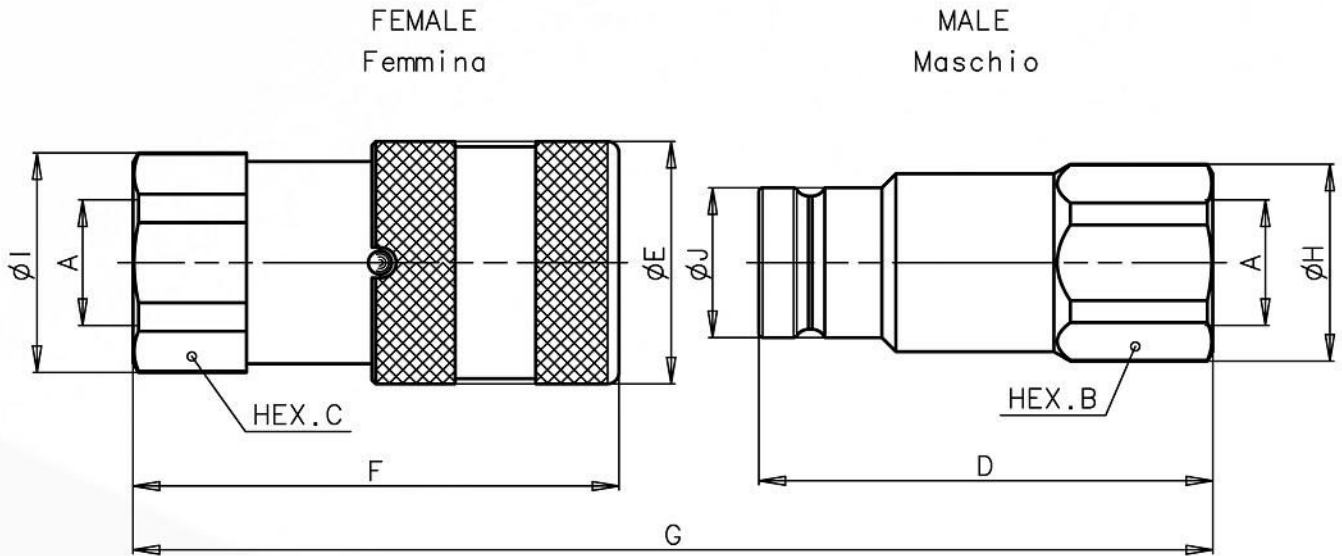

FEMALE BSPB THREAD (DIN 3852)

Description	A	Unit	B	C	D	E	F	G	H	I	J	Unit	Weight	
													Male	Female
FIRG14Q BSP	1/4	mm Inch	22 0,87	22 0,87	47,9 1,89	28 1,10	48,1 1,89	85,2 3,35	23,8 0,94	24 0,94	16,1 0,63	Kg lb	0,086 0,19	0,140 0,31
FIRG38Q BSP	3/8	mm Inch	24 0,94	27 1,06	60 2,36	32 1,26	64,2 2,53	108,7 4,28	26 1,02	29 1,14	19,7 0,78	Kg lb	0,122 0,27	0,233 0,51
FIRG12Q BSP	1/2	mm Inch	27 1,06	27 1,06	62,5 2,46	32 1,26	69,2 2,72	116,2 4,57	29 1,14	29 1,14	19,7 0,78	Kg lb	0,120 0,26	0,230 0,51
FIRG12AQ BSP	1/2	mm Inch	32 1,26	32 1,26	68 2,68	38 1,50	73,8 2,91	124,5 4,90	33,8 1,33	33,8 1,33	24,5 0,96	Kg lb	0,230 0,51	0,370 0,82
FIRG34Q BSP	3/4	mm Inch	36 1,42	36 1,42	70,5 2,78	38 1,50	80,8 3,18	134 5,28	38,5 1,52	38,5 1,52	24,5 0,96	Kg lb	0,230 0,51	0,370 0,82
FIRG34BQ BSP	3/4	mm Inch	36 1,42	36 1,42	70,5 2,78	42 1,65	78,5 3,09	131,4 5,17	38,5 1,52	38,5 1,52	27 1,06	Kg lb	0,268 0,59	0,471 1,04
FIRG100Q BSP	1	mm Inch	45 1,77	45 1,77	82,3 3,24	48 1,89	93,2 3,67	153,5 6,04	47,8 1,88	47,8 1,88	30 1,18	Kg lb	0,395 0,87	0,765 1,69
FIRG114Q BSP	1-1/4	mm Inch	55 2,17	55 2,17	89,8 3,54	55 2,17	106 4,17	172,8 6,80	59,8 2,35	59,8 2,35	36 1,42	Kg lb	0,643 1,42	1,200 2,65
FIRG112Q BSP	1-1/2	mm Inch	70 2,76	65 2,56	111 4,37	80 3,15	132,4 5,21	214,8 8,46	76 2,99	72 2,83	57 2,24	Kg lb	1,862 4,10	2,823 6,22
FIRG200Q BSP	2	mm Inch	75 2,95	80 3,15	123,8 4,87	100 3,94	156,6 6,17	241,5 9,51	83,5 3,29	88,5 3,48	73 2,87	Kg lb	2,259 4,98	5,100 11,24

OVERALL DIMENSIONS

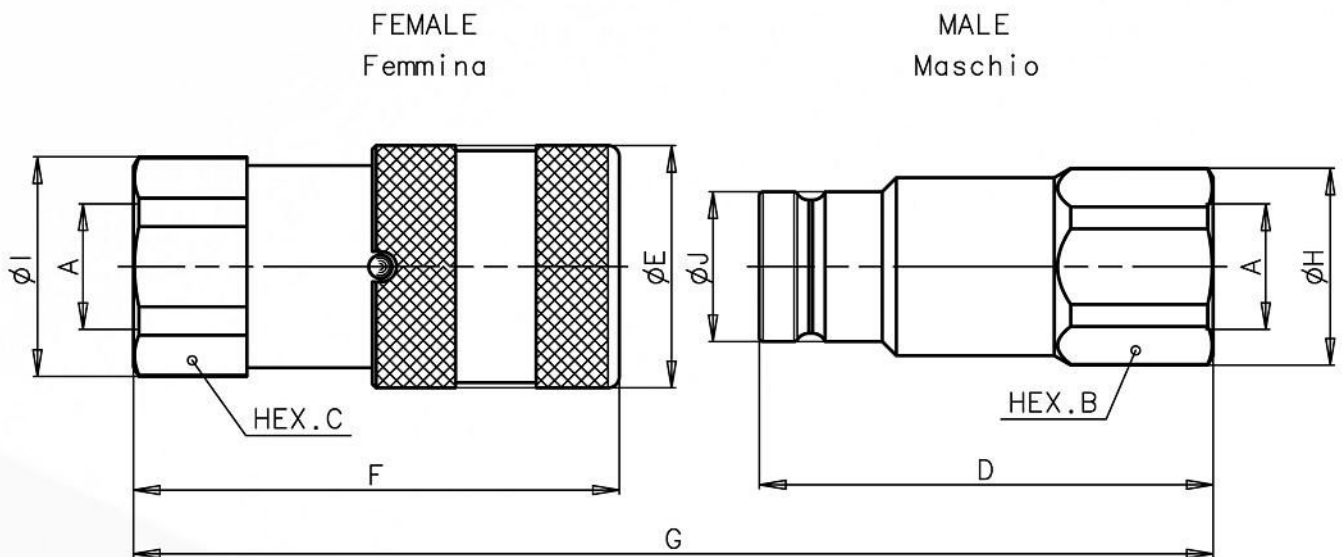

FEMALE NPT THREAD (ANSI B.1.20.3)

Description	A	Unit	B	C	D	E	F	G	H	I	J	Unit	Weight	
													Male	Female
FIRG14Q NPT	1/4	mm Inch	22 0,87	22 0,87	47,9 1,89	28 1,10	48,1 1,89	85,2 3,35	23,8 0,94	24 0,94	16,1 0,63	Kg lb	0,085 0,19	0,135 0,30
FIRG38Q NPT	3/8	mm Inch	24 0,94	27 1,06	60 2,36	32 1,26	64,2 2,53	108,7 4,28	26 1,02	29 1,14	19,7 0,78	Kg lb	0,120 0,26	0,240 0,53
FIRG12Q NPT	1/2	mm Inch	27 1,06	27 1,06	62,5 2,46	32 1,26	69,2 2,72	116,2 4,57	29 1,14	29 1,14	19,7 0,78	Kg lb	0,130 0,29	0,236 0,52
FIRG12AQ NPT	1/2	mm Inch	32 1,26	32 1,26	68 2,68	38 1,50	73,8 2,91	124,5 4,90	33,8 1,33	33,8 1,33	24,5 0,96	Kg lb	0,239 0,53	0,384 0,85
FIRG34Q NPT	3/4	mm Inch	36 1,42	36 1,42	70,5 2,78	38 1,50	80,8 3,18	134 5,28	38,5 1,52	38,5 1,52	24,5 0,96	Kg lb	0,227 0,50	0,430 0,95
FIRG34BQ NPT	3/4	mm Inch	36 1,42	36 1,42	70,5 2,78	42 1,65	78,5 3,09	131,4 5,17	38,5 1,52	38,5 1,52	27 1,06	Kg lb	0,268 0,59	0,473 1,04
FIRG100Q NPT	1	mm Inch	45 1,77	45 1,77	82,3 3,24	48 1,89	93,2 3,67	153,5 6,04	47,8 1,88	47,8 1,88	30 1,18	Kg lb	0,406 0,90	0,765 1,69
FIRG114Q NPT	1-1/4	mm Inch	55 2,17	55 2,17	89,8 3,54	55 2,17	106 4,17	172,8 6,80	59,8 2,35	59,8 2,35	36 1,42	Kg lb	0,645 1,42	1,240 2,73
FIRG112Q NPT	1-1/2	mm Inch	70 2,76	65 2,56	111 4,37	80 3,15	132,4 5,21	214,8 8,46	76 2,99	72 2,83	57 2,24	Kg lb	1,865 4,11	2,820 6,22
FIRG200Q NPT	2	mm Inch	75 2,95	80 3,15	123,8 4,87	100 3,94	156,6 6,17	241,5 9,51	83,5 3,29	88,5 3,48	73 2,87	Kg lb	2,259 4,98	5,100 11,24

The texts, data and illustrations indicated in this catalogue, may be changed by Stucchi S.p.A at any time without notice. (CAT. FIRG-Q - EN -March 2008).